

PLEASE IN THE BUILDING COMMITTEE MEETING HELD ON 11-01-2023 & RECOMMENDED

CONDITIONALLY APPROVED THE PLAN AND NOTICE OF COMMENCEMENT OF CONSTRUCTION OF THE BUILDING IS ATTACHED

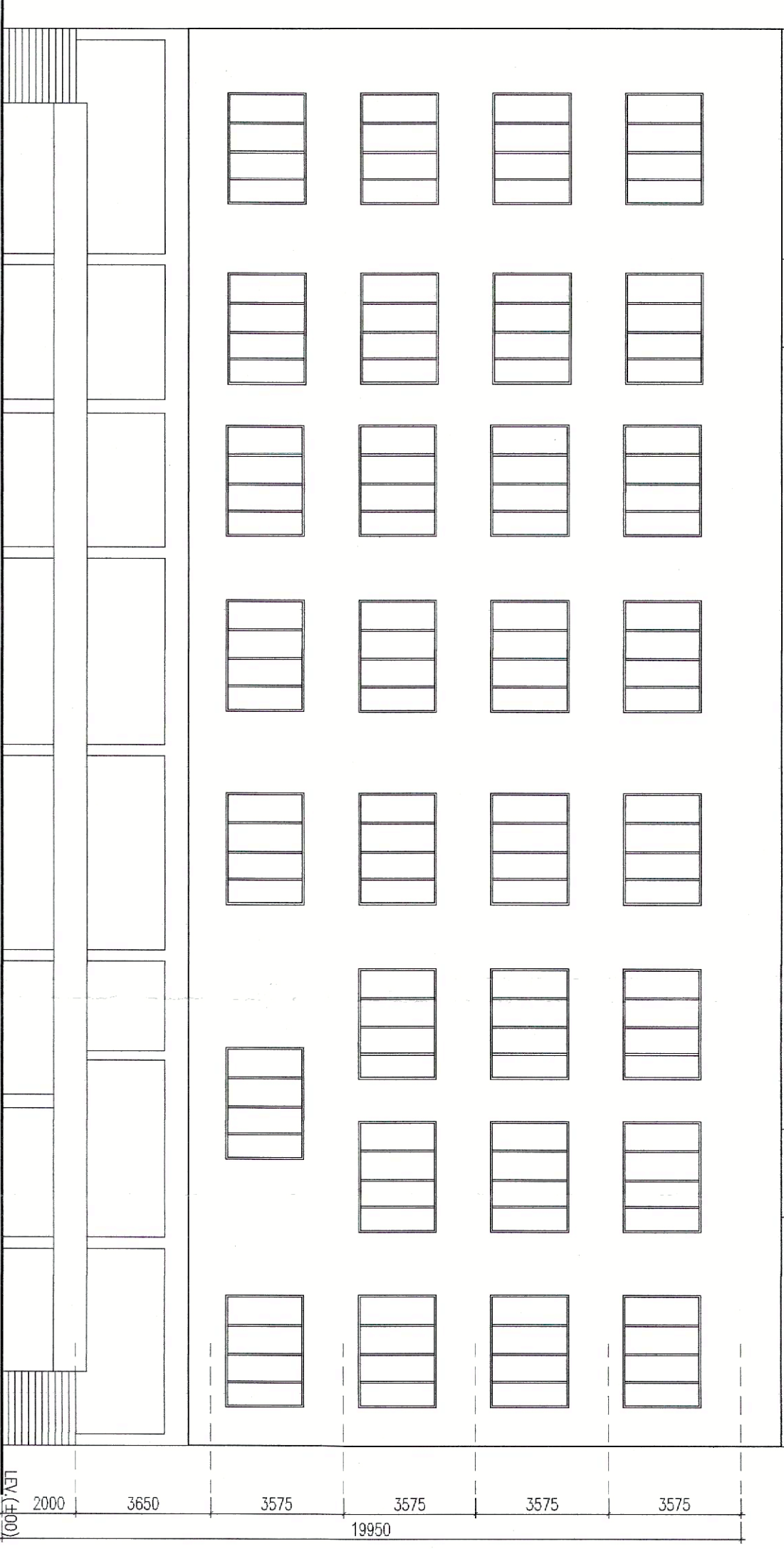

FRONT ELEVATION SCALE - 1:150

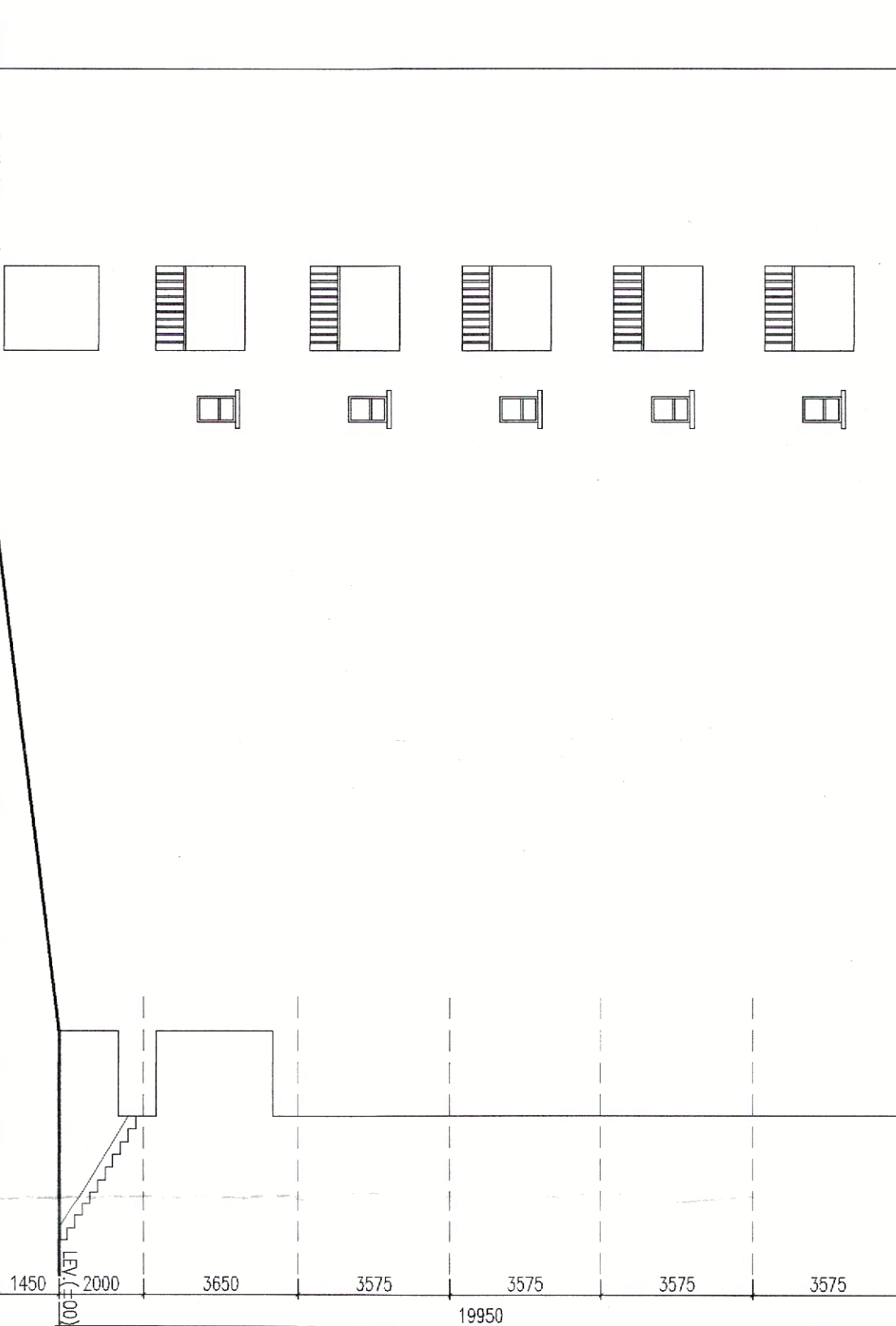

SIDE ELEVATION SCALE - 1:150

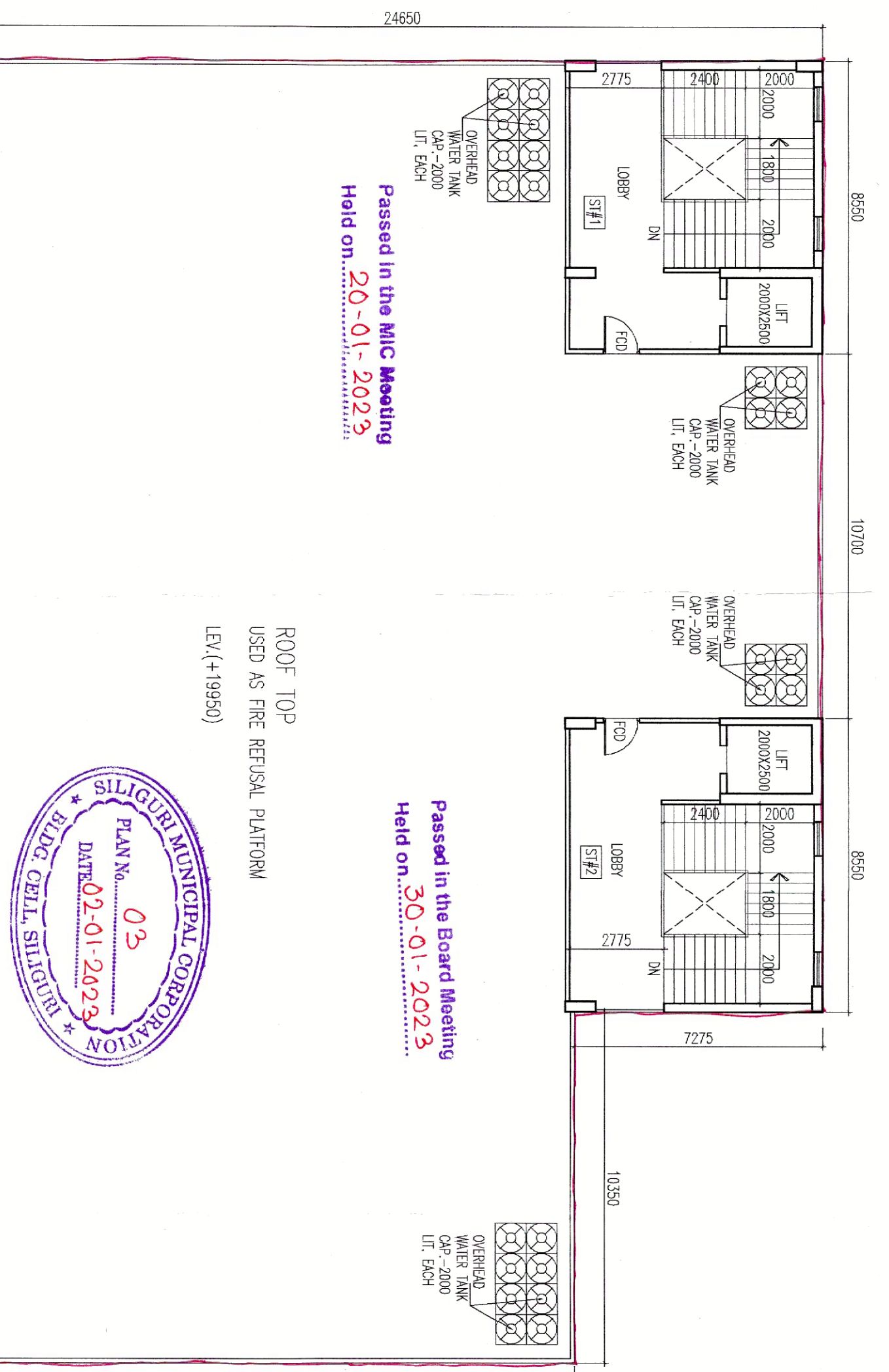

ROOF PLAN SCALE - 1:200

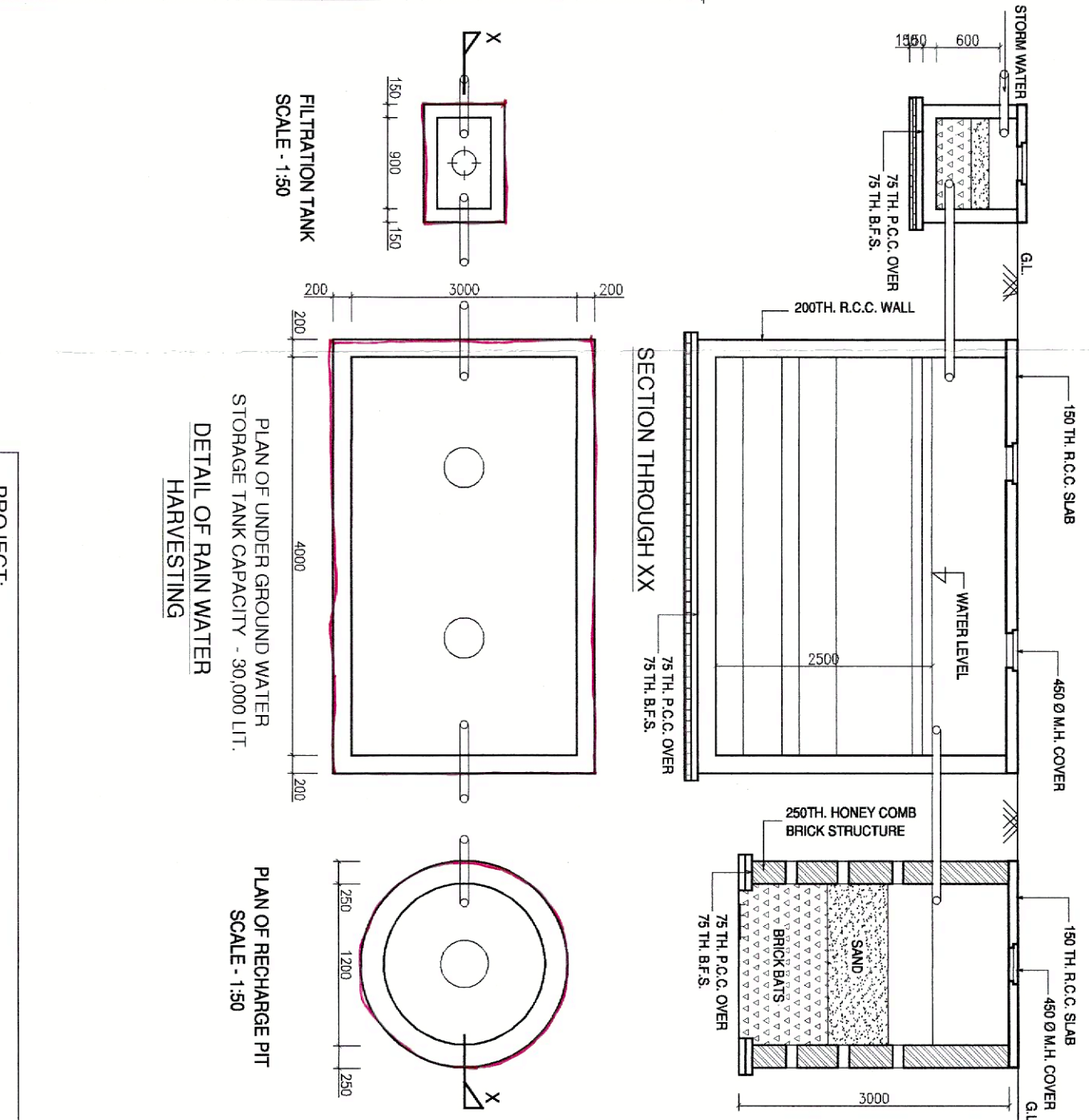

SECTION THROUGH XX SCALE - 1:50

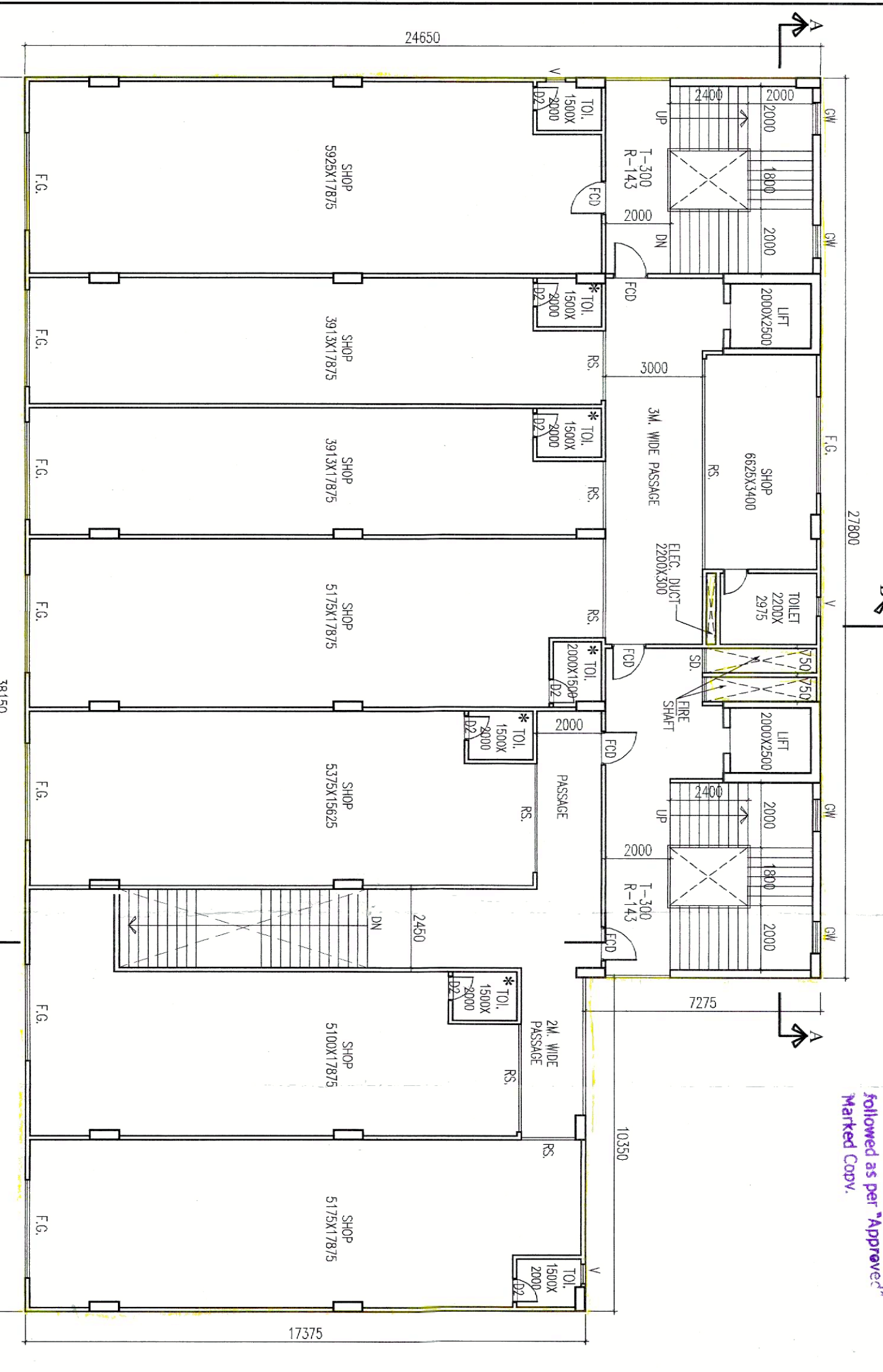

FIRST FLOOR PLAN SCALE - 1:150

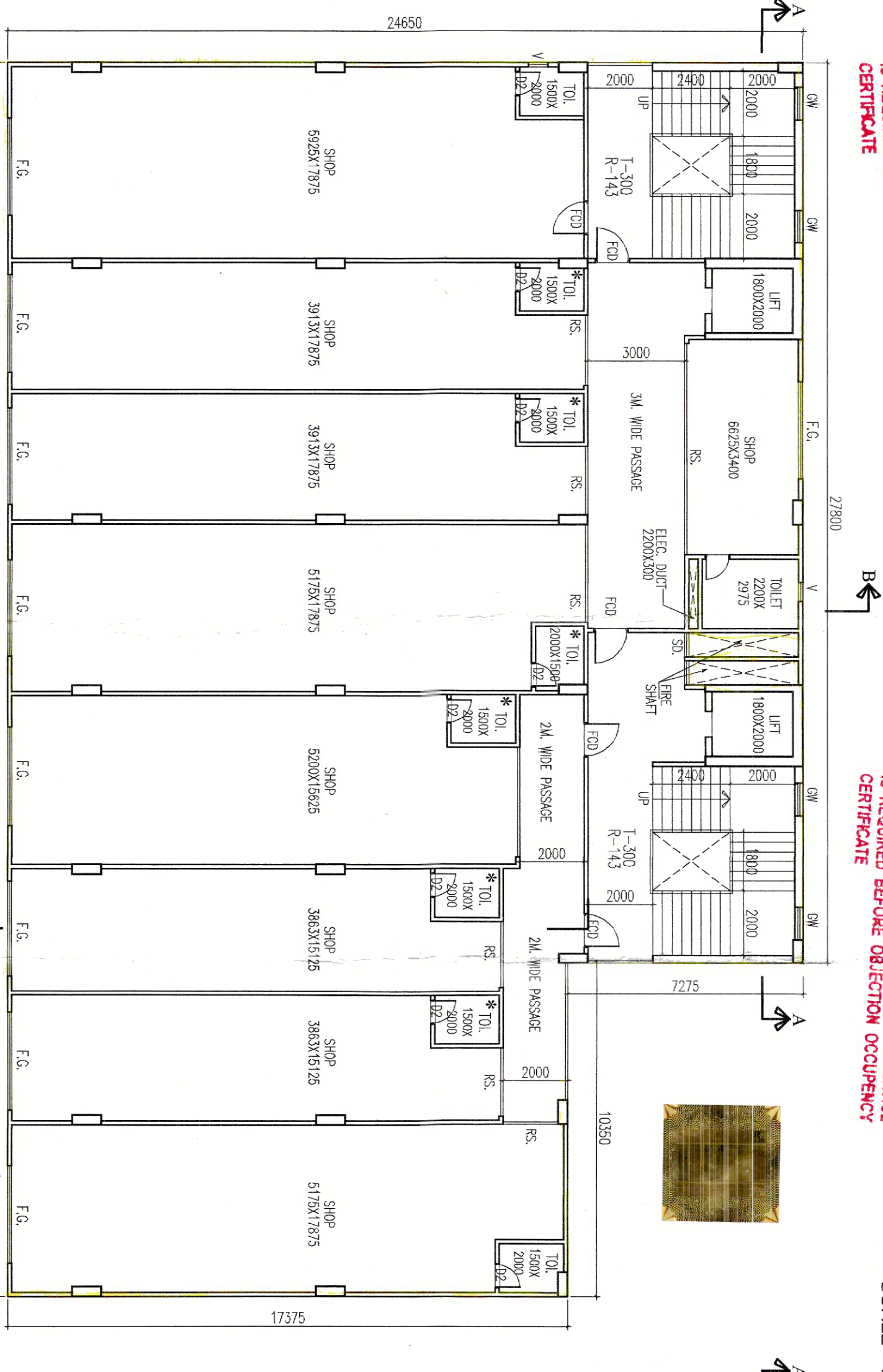

2ND FLOOR PLAN SCALE - 1:150

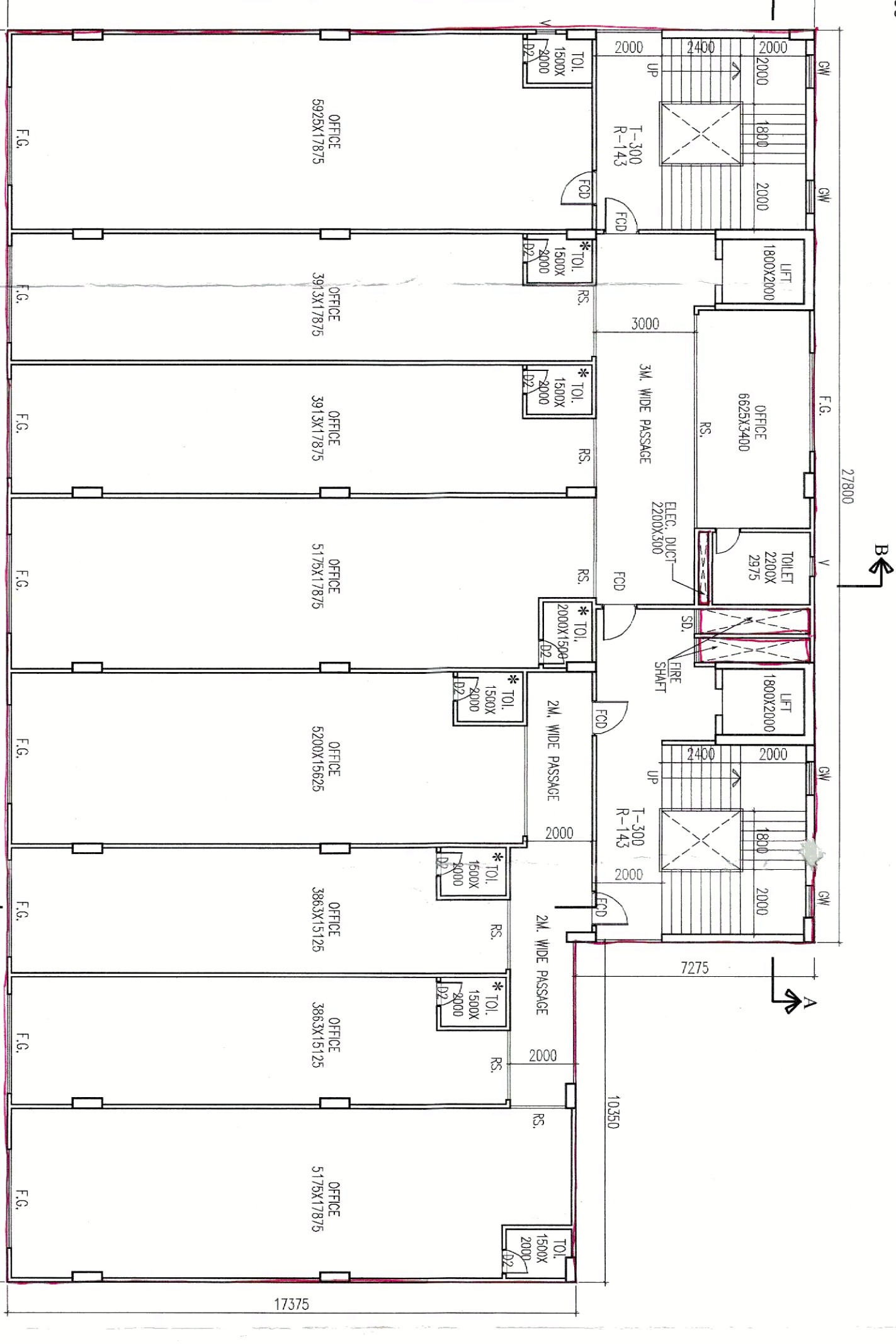

3rd & 4th FLOOR PLAN SCALE - 1:150



SECTION AT AA SCALE - 1:150



SECTION AT BB SCALE - 1:150

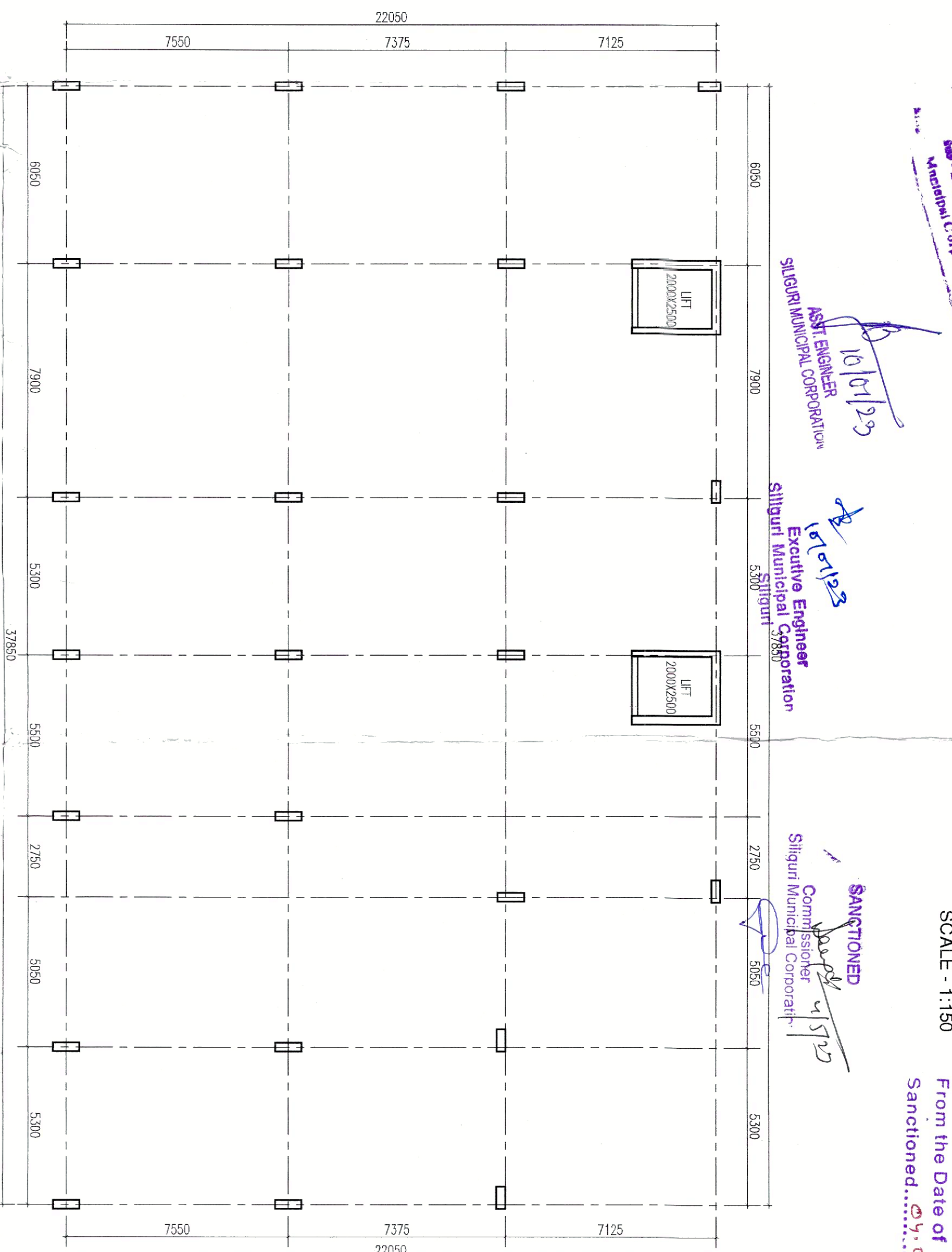

COL. LAYOUT PLAN SCALE - 1:150

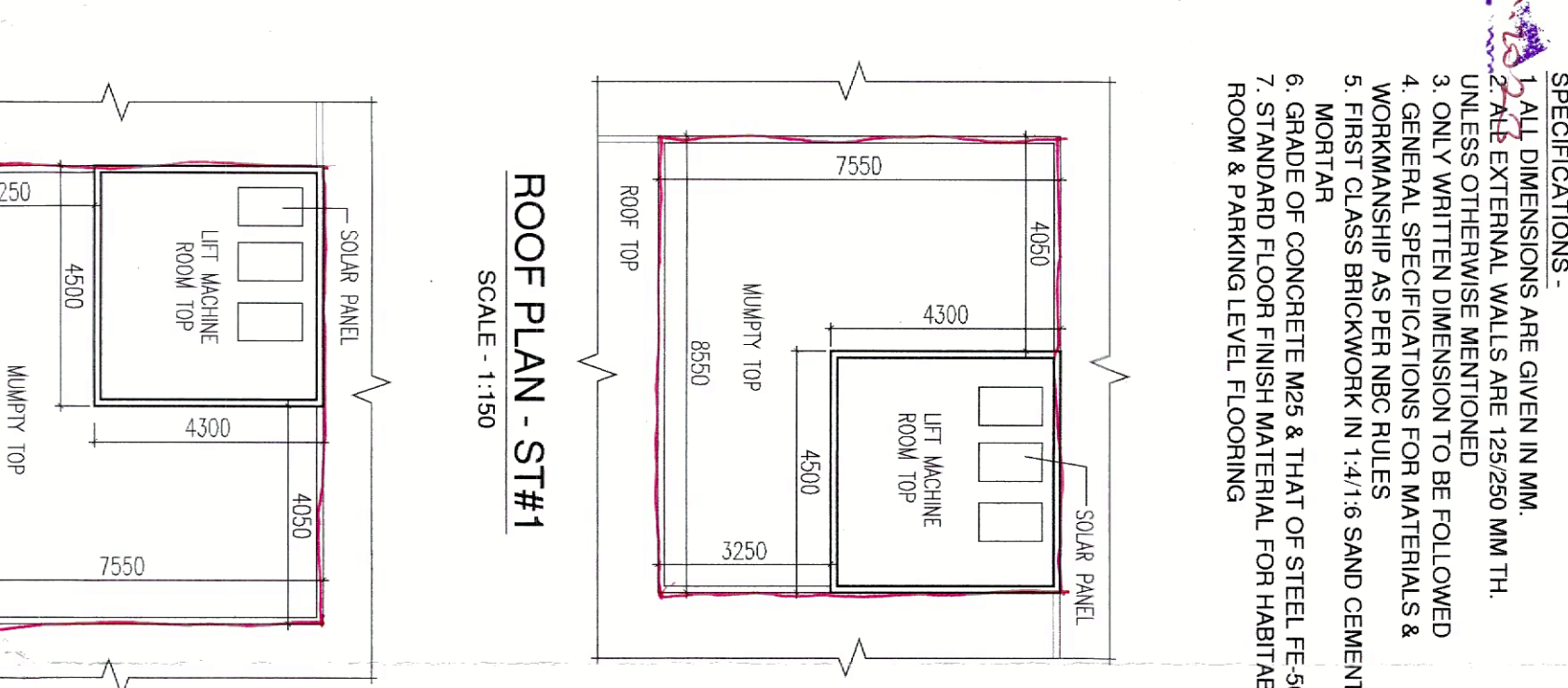

ROOF PLAN - ST#1 SCALE - 1:50

ROOF PLAN - ST#2 SCALE - 1:50

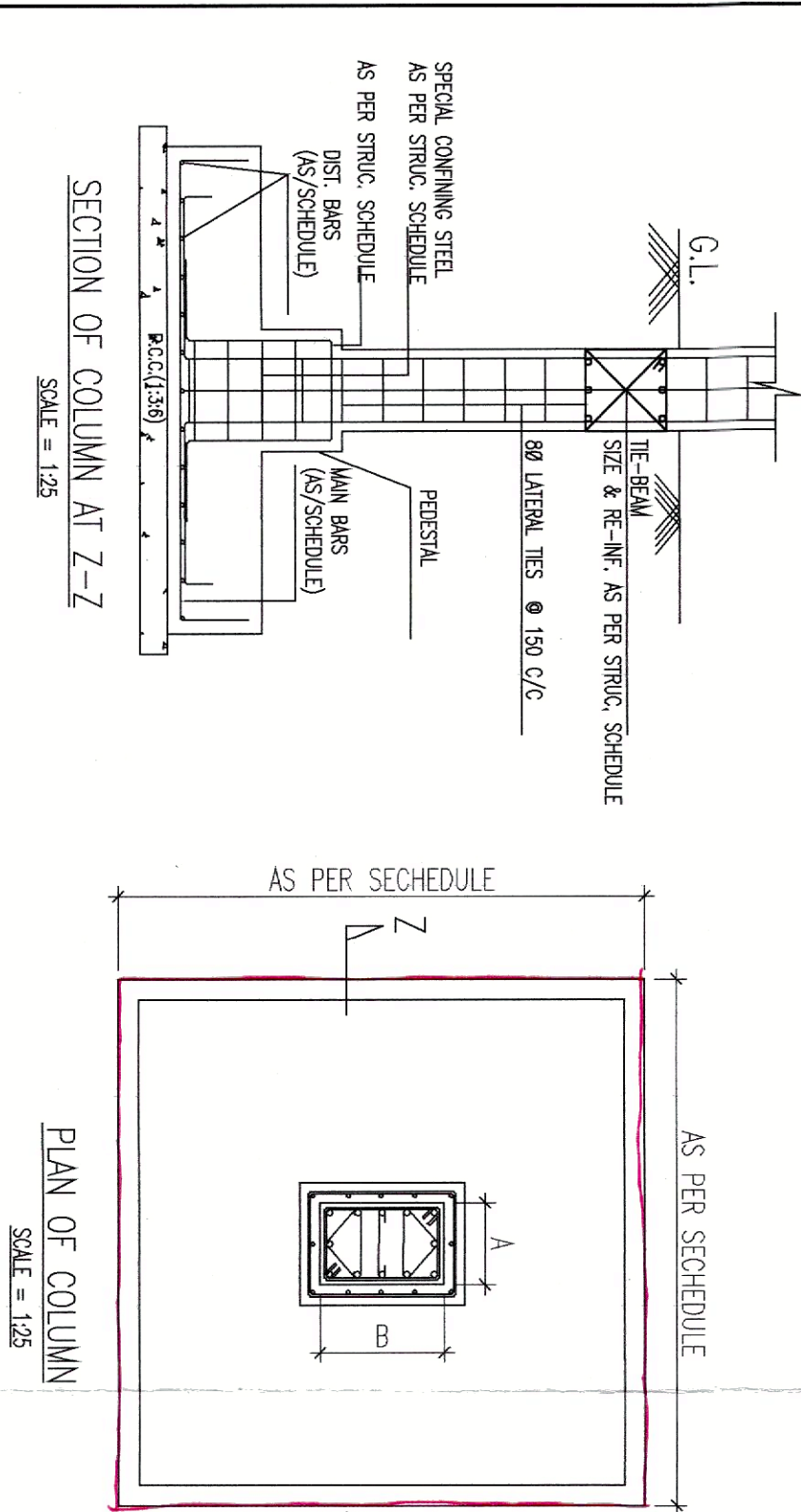

SECTION OF COLUMN AT Z-Z SCALE - 1:25

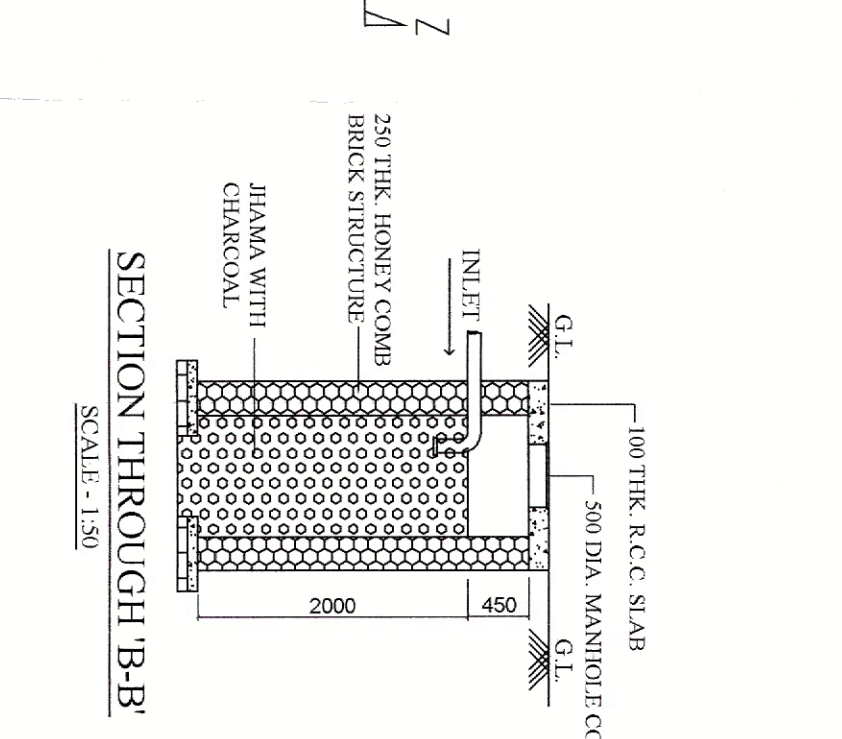

PLAN OF COLUMN SCALE - 1:25

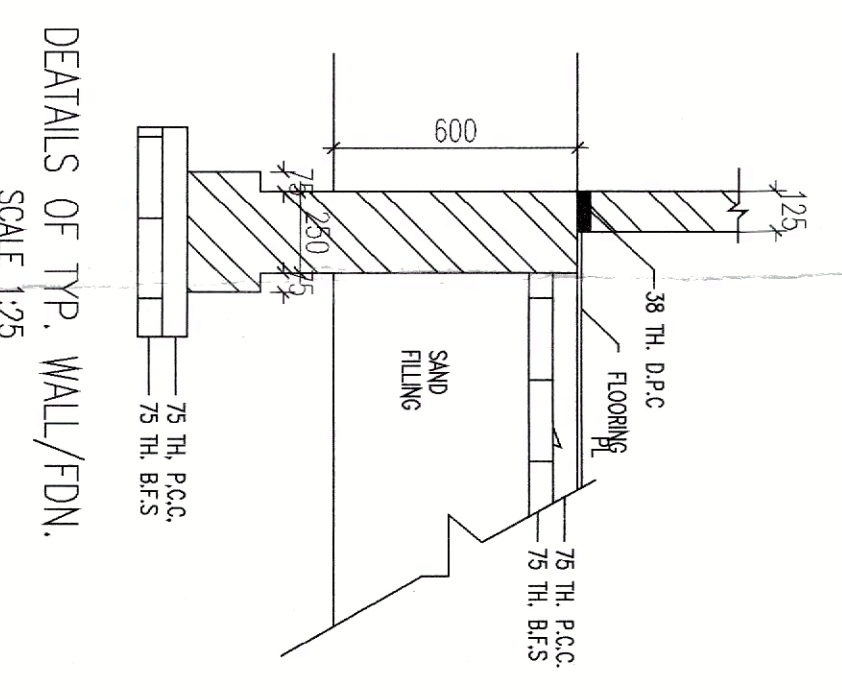

SECTION THROUGH B-B SCALE - 1:50



PLAN SOAK PIT SCALE - 1:50

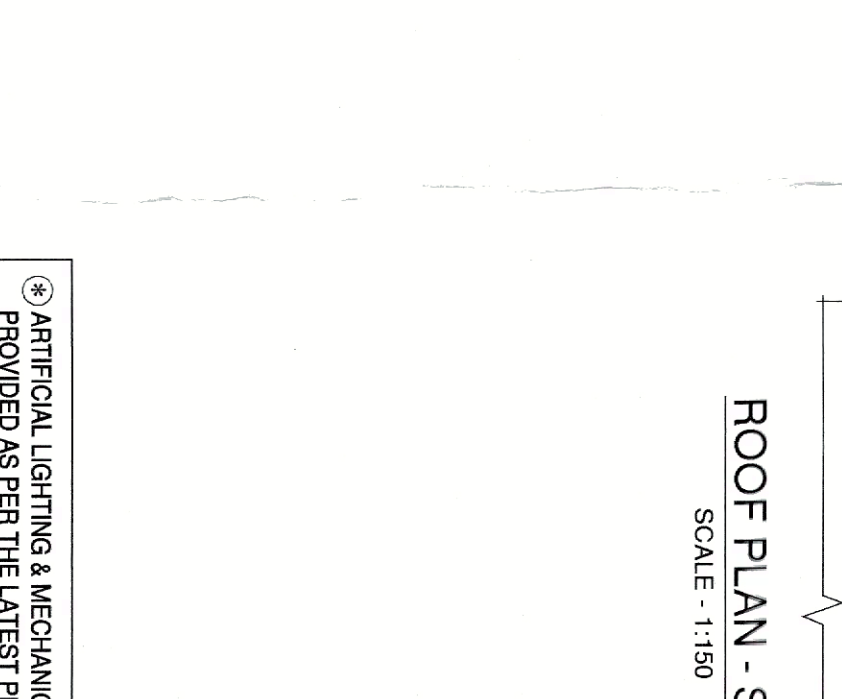

DETAILS OF TYP. WALL/FDN SCALE - 1:25

Handwritten notes and signatures in blue ink, including 'Sanctioned by Municipal Corporation' and 'Sanctioned by L.B.S. & A.B.A.'.

Sanctioned by L.B.S. & A.B.A. dated 11/01/23. Sanctioned by Municipal Corporation dated 11/01/23.

DECLARATION BY GEO. TECH. ENGR. I have examined the drawings and specifications of the building and find that they conform to the provisions of the Building Code of India and the rules and regulations thereunder.

DECLARATION BY GEO. TECH. ENGR. I have examined the drawings and specifications of the building and find that they conform to the provisions of the Building Code of India and the rules and regulations thereunder.

Project information block including: PROJECT: REVISED PROPOSED DOUBLE BASEMENT + 5 STD. COMMERCIAL BUILDING; LOCATION: BUDHWANA ROAD, NEAR SHUBANGAL BHAWAN; OWNER: SRI SANKAR KASHYAP; ARCHITECT: MAJUMDAR & ASSOCIATES; and various signatures and stamps.